



Rewarding Learning

General Certificate of Secondary Education
2022

Centre Number

--	--	--	--	--

Candidate Number

--	--	--	--

Further Mathematics

Unit 4 (With calculator)

Discrete and
Decision Mathematics



[GFM41]

GFM41

WEDNESDAY 22 JUNE, AFTERNOON

TIME

1 hour.

INSTRUCTIONS TO CANDIDATES

Write your Centre Number and Candidate Number in the spaces provided at the top of this page.

You must answer the questions in the spaces provided.

Do not write outside the boxed area on each page.

Complete in black ink only. **Do not write with a gel pen.**

All working **must** be clearly shown in the spaces provided. Marks may be awarded for partially correct solutions.

Answer **all six** questions.

INFORMATION FOR CANDIDATES

The total mark for this paper is 50.

Figures in brackets printed down the right-hand side of pages indicate the marks awarded to each question or part question.

You may use a calculator.

13066



16GFM4101

BLANK PAGE
DO NOT WRITE ON THIS PAGE

13066



16GFM4102



1 The principal of a school looked at the paintings of her 5 predecessors on the corridor wall.

(i) In how many different ways could she arrange them in a straight line?

Answer _____ [2]

(ii) If she arranged 3 of these 5 paintings in a straight line on the wall of her office, in how many ways could this be done?

Answer _____ [1]

[Turn over



- 2 A fireworks manufacturer is planning to sell a display pack containing Skyrockets and Rainbow Candles.

The details for each firework are given in the table below.

	Display time (seconds)	Mass (grams)	Profit (£)
Skyrocket	50	120	1.50
Rainbow Candle	25	100	1.00

Let x represent the number of Skyrockets in a pack.

Let y represent the number of Rainbow Candles in a pack.

At least 20 Rainbow Candles must be included in each pack.

- (i) Express this condition as an inequality.

Answer _____ [1]



The display pack must contain enough fireworks, set off one after the other, for a display of at least 35 **minutes**.

(ii) Show that

$$2x + y \geq 84$$

[2]

The mass of the display pack must not exceed 9 **kg**.

(iii) Show that

$$6x + 5y \leq 450$$

[2]

Q2 continues on page 6

[Turn over



(iv) Illustrate the three inequalities by a suitable diagram on the graph below.

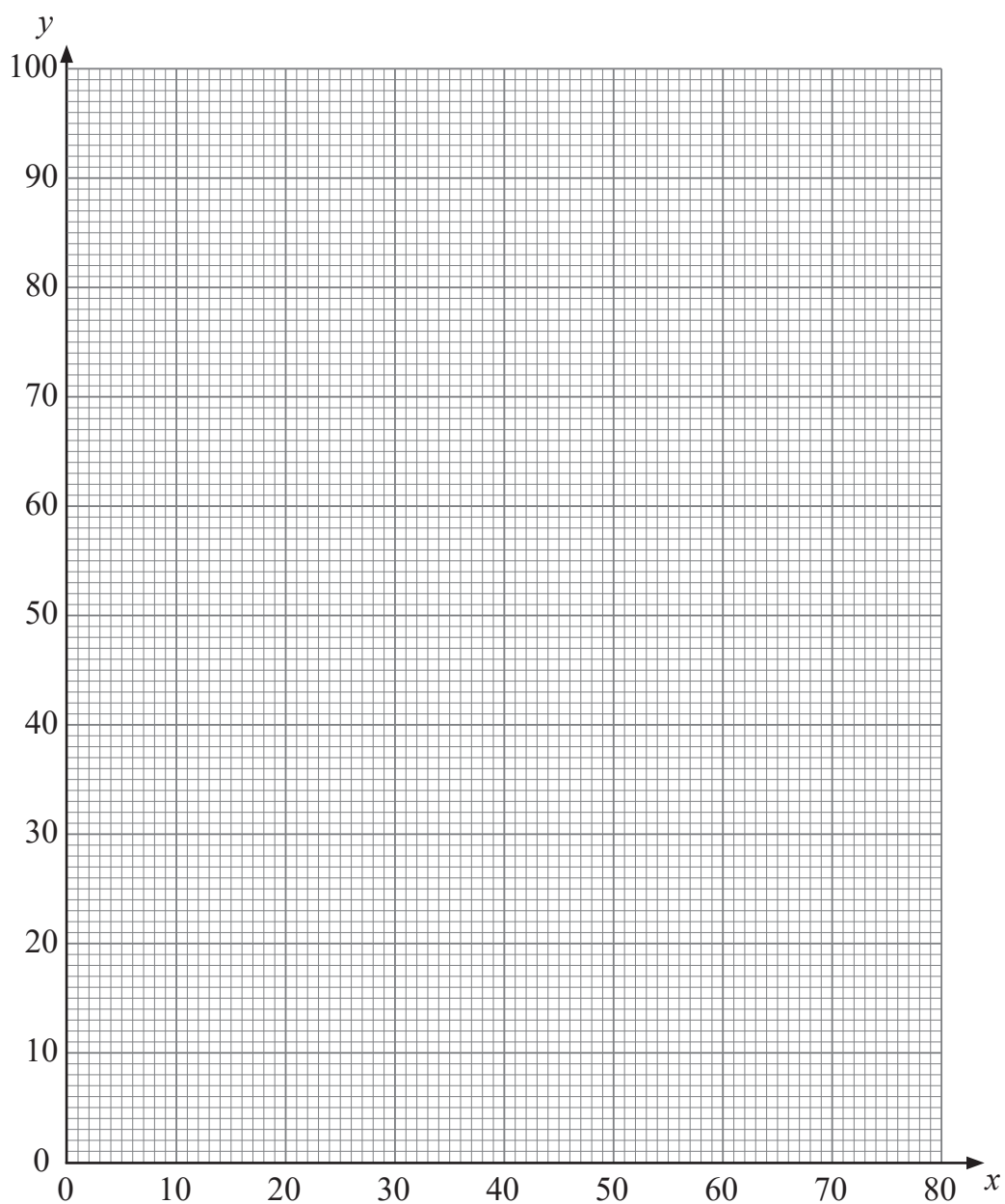

Identify with the letter **R** the region containing the set of points satisfying all three inequalities.

[3]



- (v) Use your solution set to find the numbers of each type of firework the display pack should contain to maximise the profit.

Answer Number of Skyrockets _____

Number of Rainbow Candles _____ [4]

- (vi) Hence calculate the total display time this solution would give.

Answer _____ seconds [1]

[Turn over



- 3 Sophie opened a pop-up café on weekdays in June. She recorded the number of customers each weekday for part of June.

Her results are shown in the table below.

	Week 1					Week 2					Week 3		
Day	Mo	Tu	We	Th	Fr	Mo	Tu	We	Th	Fr	Mo	Tu	We
Number of customers	101	93	88	90	98	109	100	95	98	105	116	107	103

These data have been plotted in the graph below.

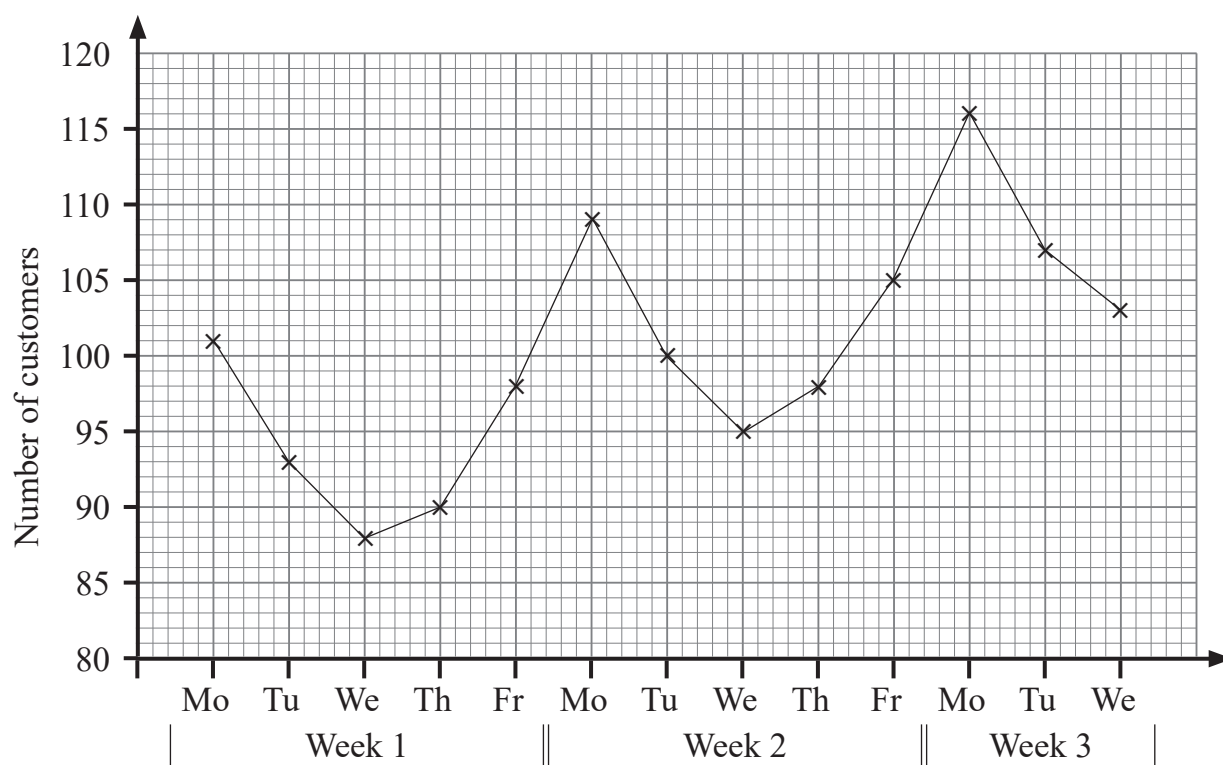

- (i) Calculate appropriate moving averages to smooth the data, using the information below.

101

93

88

90

98

109

100

95

98

105

116

107

103

[3]

- (ii) Plot these averages on the graph opposite and draw the trend line.

[3]

- (iii) Showing clearly where any reading is taken, use the trend line to calculate an estimate of how many customers Sophie is likely to expect on Thursday of Week 3.

Answer _____ [3]

[Turn over



4 (i) Complete the truth table below to show that the statements

$(p \text{ or } q) \text{ and } (p \text{ or } r)$ and $p \text{ or } (q \text{ and } r)$

are equivalent.

p	q	r	$p \text{ or } q$	$p \text{ or } r$	$(p \text{ or } q) \text{ and } (p \text{ or } r)$	$q \text{ and } r$	$p \text{ or } (q \text{ and } r)$
T	T	T					
T	T	F					
T	F	T					
T	F	F					
F	T	T					
F	T	F					
F	F	T					
F	F	F					

[6]



The Boolean variables p , q and r are such that

p denotes “Adam loves cheese”,

q denotes “Bernie hates football”,

r denotes “Cally plays table tennis”.

(ii) Using part (i), write down an equivalent version of the compound statement

“Adam loves cheese or Bernie hates football,
and,
Adam loves cheese or Cally plays table tennis.”

Answer _____

_____ [2]

[Turn over



- 5 In a primary school pantomime there are
7 fairies,
8 elves, and
6 pixies.

The first scene requires

- 2 fairies,
3 elves, and
3 pixies.

- (i) In how many ways can this be done?

Answer _____ [4]



A hero, a villain and a joker are chosen from the 14 elves and pixies.

The second scene requires the hero, the villain, the joker and 4 fairies.

(ii) In how many ways can this be done?

Answer _____ [4]



- 6 The diagram below shows the activity network used to model a sound recording project. The activities involved are labelled A, B, C, D, E, F and G and are represented by the edges.

Each activity requires one staff member.

The number on each edge represents the time in hours required to complete that activity.

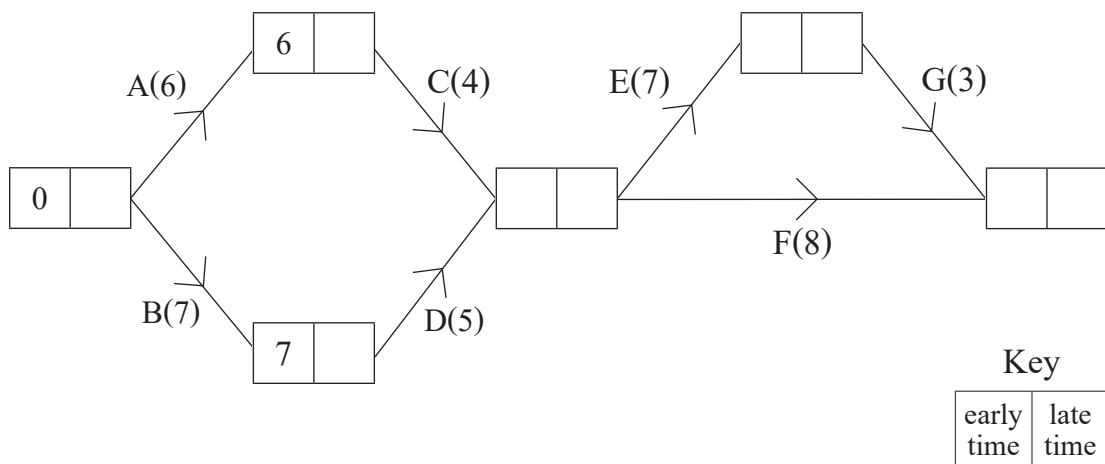

- (i) Complete the diagram above by filling in the missing early times and late times.

[4]

- (ii) List the critical activities and determine the length of the critical path.

Answer Critical activities _____ [1]

Length of critical path _____ hours [1]



DO NOT WRITE ON THIS PAGE

For Examiner's use only	
Question Number	Marks
1	
2	
3	
4	
5	
6	

Total Marks	
--------------------	--

Examiner Number

Permission to reproduce all copyright material has been applied for.
In some cases, efforts to contact copyright holders may have been unsuccessful and CCEA will be happy to rectify any omissions of acknowledgement in future if notified.

13066/4



16GFM4116